

# AZURA BASS HORN 2 - CUTTING DIMENSIONS

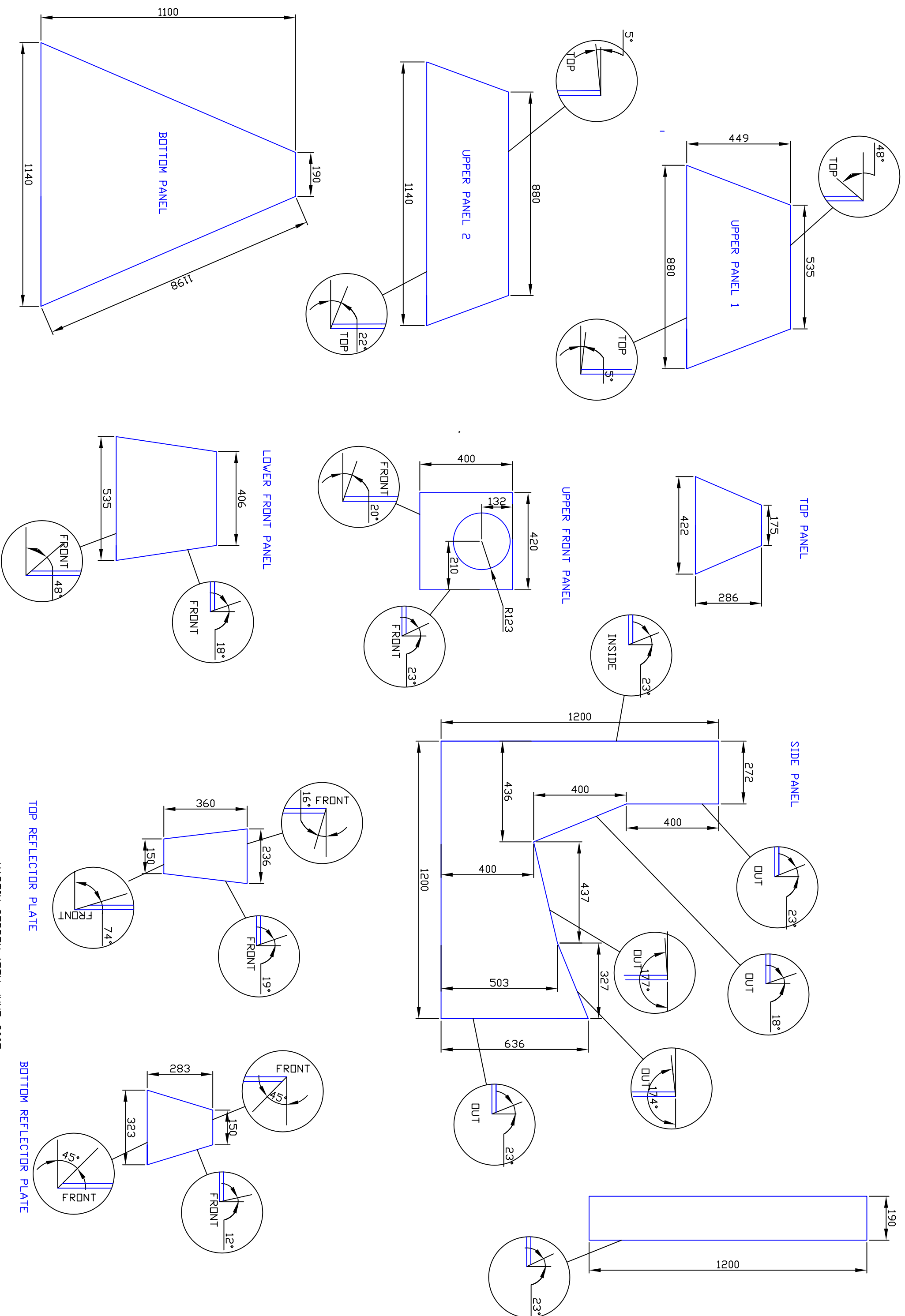

# AZURA BASS HORN 2 - PLAN & ELEVATION

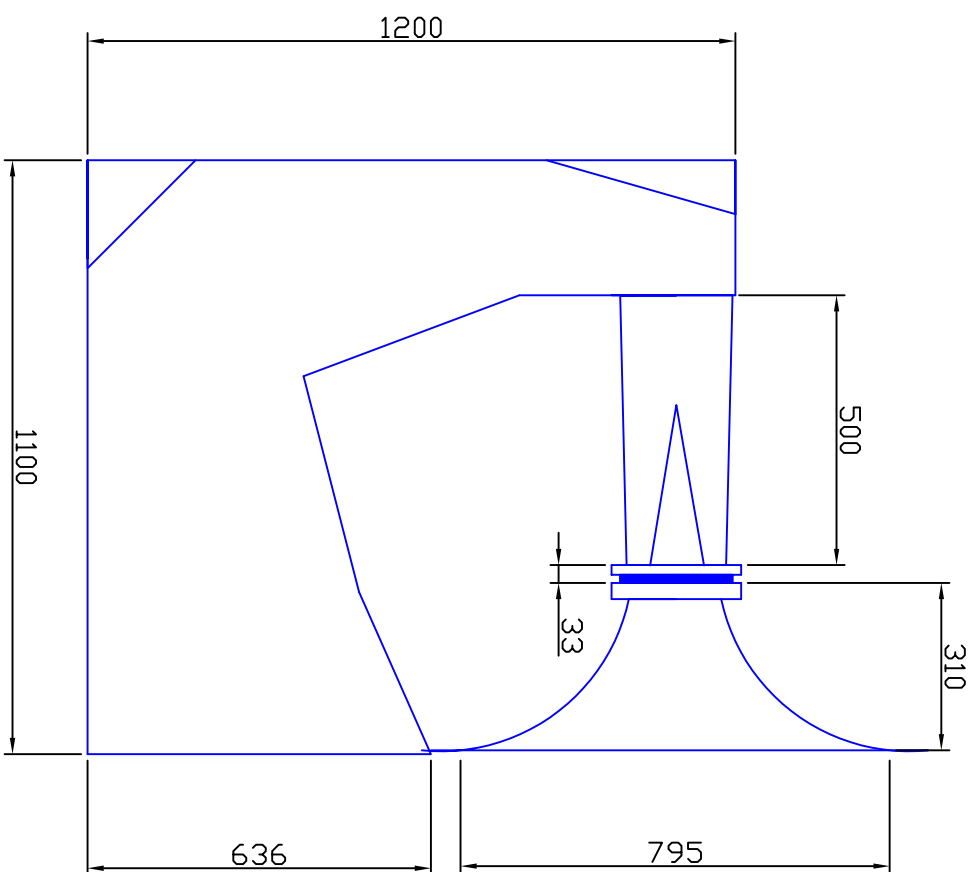
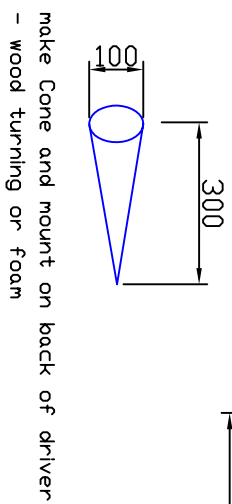
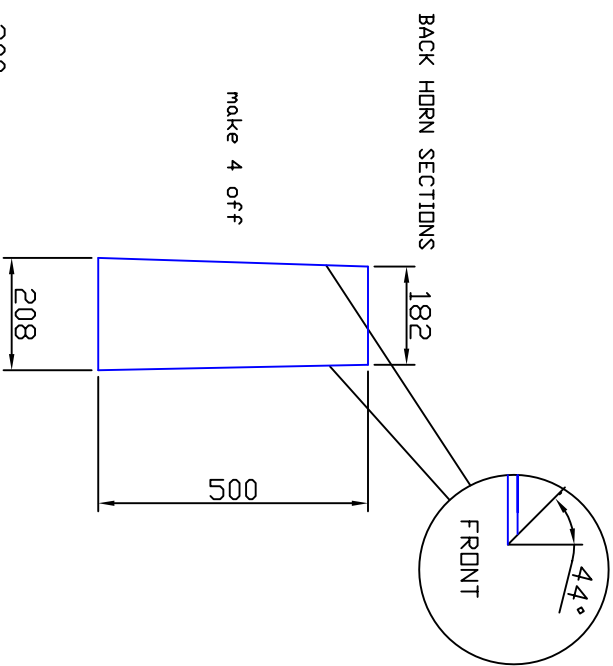
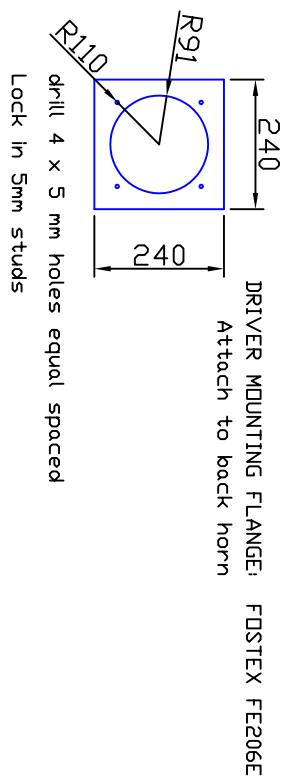

INTERNAL DIMS SHOWN (MM)

MARTIN SEDDON 21st OCT 2005

# AZURA BASS HORN 2 - PLAN & ELEVATION

